

CHOP CUTTER VORTEX

WFC-V360



Faster and more beautiful slice.

The most artistic frozen-meat slicer in the world has been finally launched.



CAPACITY
380 slices/min.
MAX

IMPROVED SLICE QUALITY

Outstanding better operation efficiency. The finest accuracy and the most artistic slice edge in the world.

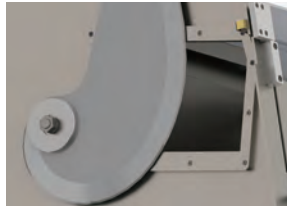

SAFETY SYSTEM

Not only the interlock system, but also safety device to detach the blade (Option) and safety sensor give you more safety operation.



MORE PRODUCT YIELD

Less meat dust inside of the blade cover. New meat catcher achieves less slice loss, the least is 20mm. Modify it 20, 30, or 40mm depends on the products without any tools.



SLICE CAPACITY

The maximum 380 slices/min. is available.



OPTION

MEAT CATCHER SYSTEM

Sliced productions are 'CATCHED' by the air pressure drive. This helps to decrease more labor costs.



※The air compressor will be needed.

SCATTERING STOPPER

The scattering and curls are refrained from the beginning to the end of the slice. The small meat is also possible to be sliced without any slippage.

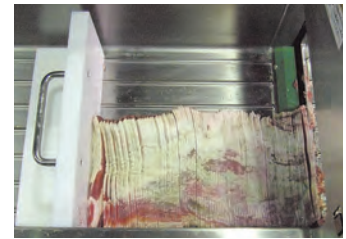

WITH CONVEYOR

The conveyor can be attached on the outlet part. It will contribute the automation line.



■DRAWING

Please refer to the drawing for further information.

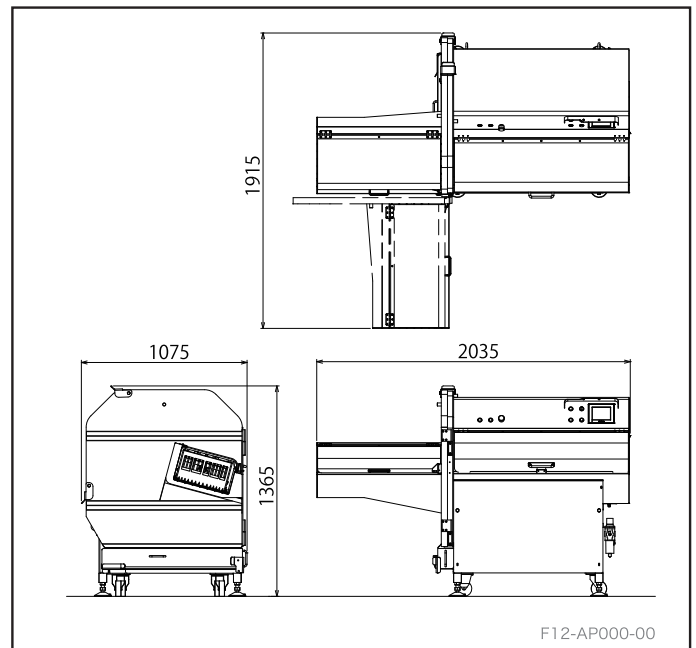

■SPECIFICATION

DIMENSIONS	W2035×D1075×H1365mm
MAX. SLICE SIZE	W360×H200×L630mm
SLICE THICKNESS	~30mm
CAPACITY	100~380slice/min
SLICE TEMPERATURE	-6~-2°C ((Depends on product)
SLICE ANGLE	0°(Fixed)
RATED ELECTRICITY	Output: 5.2kW Pated electric current : 26A
RATED CONSUMPTION	1.1 kW (50/60Hz with no load)
POWER SUPPLY	3P 200V 50/60Hz more than 30A

WATANABE
WATANABE FOODMACH CO.,LTD.

2-12-26 TSUYUHASHI NAKAGAWA-KU NAGOYA JAPAN
TEL052-361-8511 FAX052-361-8490
URL : <http://www.foodmach.co.jp/>

SALES AGENT