

SHARK350

WAB35-3C



SIMPLE TO USE AND THE SAFETY DESIGN



A TABLE 850MM TALL : KIND DESIGN TO ALL USERS

The height of a table is 850mm. This design is considered for all users and everyday work.

THE BLADE GUIDE STOPPER WITH GREAT SECURITY

The blade guide stopper is designed to hardly trip in case screws for the stopper unfasten, leading to great security to use.

THE SOLID SAFETY

The interlock system for upper and lower doors prevents the accidental start of the machine.

THE BRAKE MOTOR SYSTEM (OPTION)

Time from the machine stoppage to the complete stop of a blade is shortened by the effective use of the brake motor system.

■ SPECIFICATION

MODEL	WAB35-3C
DIMENSIONS	W920×D1135×H1635mm
INSTALLED FLOOR SPACE	W455×D690mm
TABLE SIZE	Fixed side:W390×D890mm Movable side:W380×D530mm
SLICE SIZE	W345XH300mm
BLADE DIAMETER(STANDARD)	W16XL2600XT0.5mm
BLADE SPEED	1617m/min(50Hz) 1945m/min(60Hz)
POWER SUPPLY	3-phase 200V 1.5kW
PULLEY SIZE	350mm
MACHINE WEIGHT	150 kg

■ DRAWING Please refer to the drawing for further information .

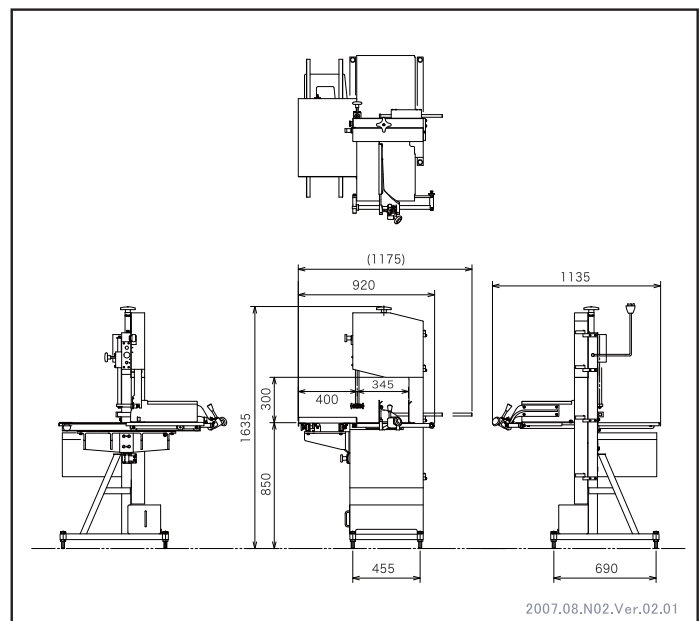

WATANABE
WATANABE FOODMACH CO.,LTD.

2-12-26 TSUYUHASHI NAKAGAWA-KU NAGOYA JAPAN
TEL052-361-8511 FAX052-361-8490
URL : <http://www.foodmach.co.jp/>

SALES AGENT