

# FROZEN SEPARATOR WCC-FZ



More yield on the primal process, and safer in the operation



# New option for frozen meat processing!!

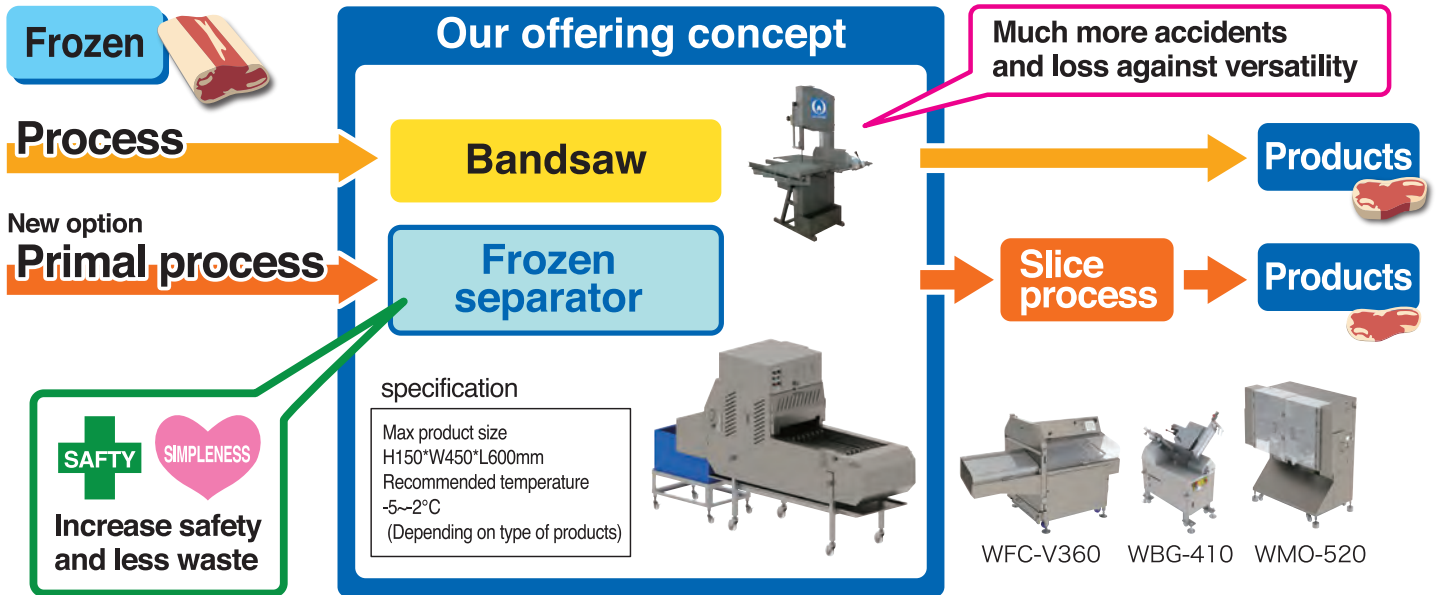

## ⚠ Caution for Usage

- Always pay attention to a blade and a rotating parts.
- Lead the ground terminal to an earth leakage.
- Do not operate with products which is not in manual.
- Unplug the power while unoccupied.
- Be sure to operated without problems.

## ■ SPECIFICATION

DIMENSIONS	W2,810×D890×H1,620mm
WEIGHT	445kg
MAX. SLICE SIZE	W450×H150×L600mm
SLICE THICKNESS	Cut in half
CAPACITY	10 times/min
SLICE TEMPERATURE	-5~-2°C ((Depends on product)
RATED ELECTRICITY	Output 1.92kW Pated electricity current 9.2/8.5A (50/60Hz)
RATED POWER CONSUMPTION	0.35kW/0.3kW (50/60Hz with no load)
POWER SUPPLY	3P 200V 50/60Hz more than 20A

■ DRAWING Please refer to the drawing for further information .

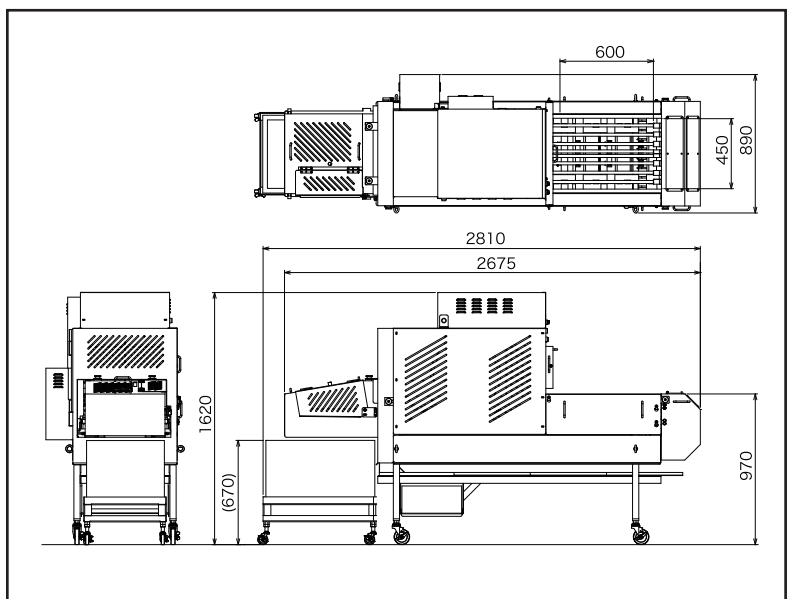

**WATANABE**  
WATANABE FOODMACH CO.,LTD.

2-12-26 TSUYUHASHI NAKAGAWA-KU NAGOYA JAPAN  
TEL052-361-8511 FAX052-361-8490  
URL : <http://www.foodmach.co.jp/>

SALES AGENT