

PROCEED DX

WMB-P330DX



STANDARD & ECONOMICAL TYPE



Safety

A lever with a safety lock system safely starts the locking system with a equipped emergency stop button.



A equipped safety stop system blade and tank does not move with the unfastened side board prevent danger at the washing.



Simplicity

Easy loading for a bigger size product. And easy open up an upper roller set by 2 step motion.



Simply adjusting a slice thickness using just one knob from 0 to 11mm.



It is equipped a meat side plate with a range from 100 to 330mm wide.



Satisfaction

Friendly concerned to swing up an upper roller set by mounted a support spring.



■ SPECIFICATION

DIMENSIONS	W1035xD1110xH1425mm
POWER SUPPLY(BLADE)	3-phase 200V 0.4kW
POWER SUPPLY(CARRIAGE)	3-phase 200V 0.75kW
SLICE CAPACITY	40~65slices/min
MAX SIZE OF SLICES	W330xH180xL700mm
MAX LOAD at MAX SPEED	12kg
SLICE THICKNESS	~11 mm
TEMPERATURE	-2~5°C (depends on products)
BLADE	φ390mm
MACHINE WEIGHT	275kg

Sanitation

THE ONE-TOUCH DETACHABLE ROLLER BY TOUCHING JUST ONCE.

The easy detachable roller with only loosening knob. Easy for everyone.



PARTS CAN BE EASILY DISASSEMBLED WITHOUT ANY TOOLS.

They can be washed at the sink. No need any tool for cleaning. Parts are a few and cleaning is easy.



Skill

Using a timing belt for an accurated slice and a chain for a certain feeding by an upper roller.



The equipped inverter system and easy to change the speed. Just turn knob for adjusting speed, less vibration and highly quiet.



It keeps a super sharp edge blade by the grinding stone which could be tilted while not using.



■ DRAWING

Please refer to the drawing for further information.

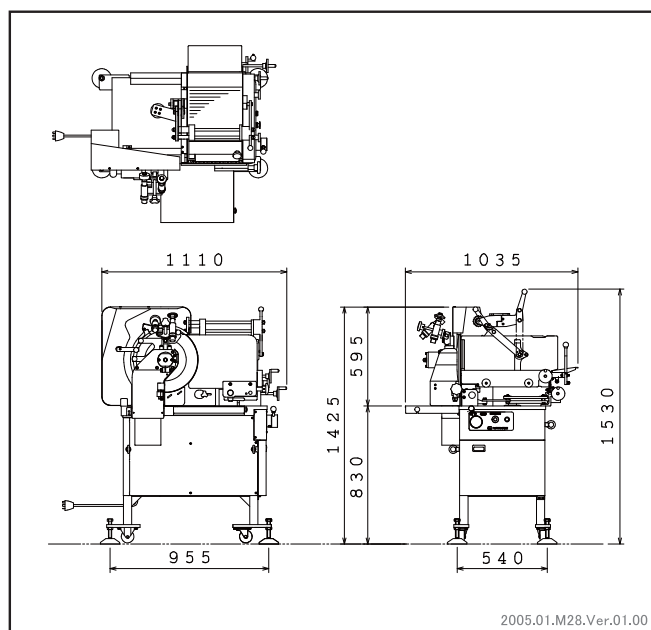

WATANABE
WATANABE FOODMACH CO.,LTD.

2-12-26 TSUYUHASHI NAKAGAWA-KU NAGOYA JAPAN
TEL052-361-8511 FAX052-361-8490
URL: <http://www.foodmach.co.jp/>

SALES AGENT