

GREAT MINI MINCE M22E-2/M12E-2 WMG-M22E-2/M12E-2



WATANABE SPECIAL BARREL KEEPS THE FRESHNESS OF MEATS AFTER GRINDED!!



WMG-M22E-2



WMG-M12E-2

SPECIAL BARREL

THE FEEDSCREW AND BARREL ARE CARTRIDGE TYPE

BOX TYPE

COMPACT DESIGN

KEEP FRESHNESS OF MEATS WELL!

The special barrel keeps the freshness of products.

WELL SANITARINESS

The barrel, feeding screw, locking ring, and meat tray are all stainless steel made.

EASY TO ATTACH/ DETACH THE BARREL AND FEEDING SCREW

Only one lever for attaching/detaching them. Easy to be cleaned up!

Foot switch (Optional)



*An extra electrical box is needed.

■DRAWING Please refer to the drawing for further information .

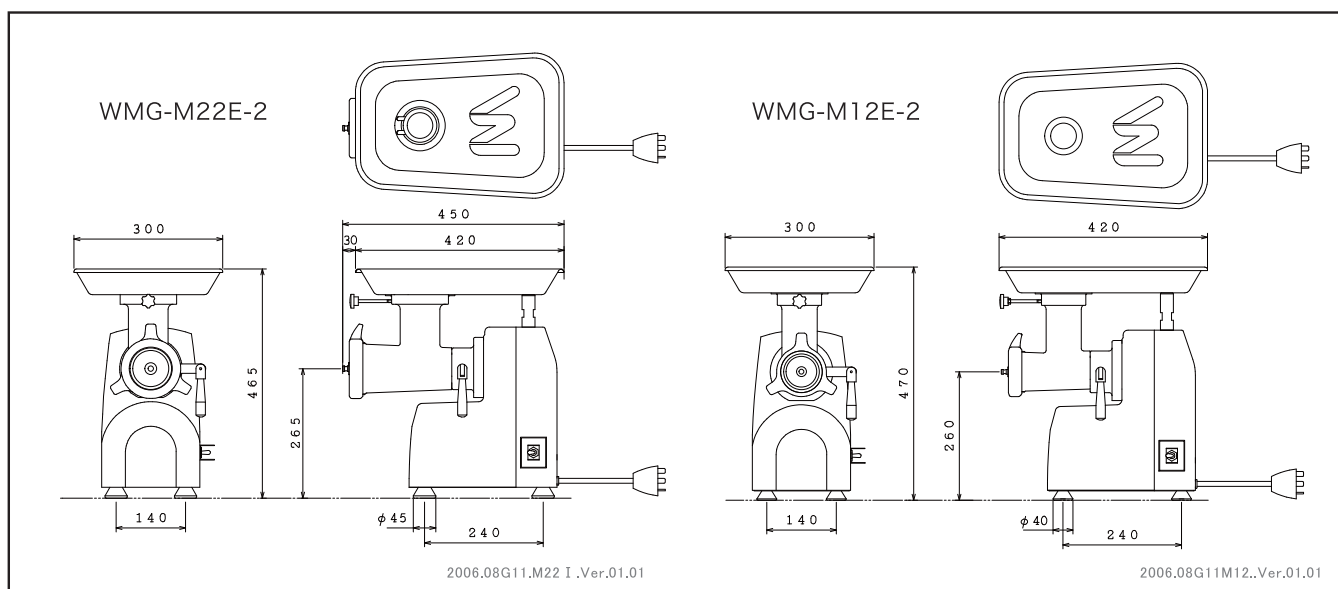

■SPECIFICATION

MODEL NO.	WMG-M22E-2	WMG-M12E-2
DIMENTION	W300×D450×H465mm	W300×D420×H470mm
MAX. PROCESS SIZE	φ50 mm・□35 mm	φ50 mm・□35 mm
PROCESS AMOUNT	MAX.300KG (3.2mm plate)	MAX.150KG (3.2mm plate)
MOTOR	1P 230V 0.5 kW	1P 230V 0.5 kW
TEMPERATURE	More than -4°C (DEPENDS ON MEAT, SHAPE and THICKNESS)	More than -4°C (DEPENDS ON MEAT, SHAPE and THICKNESS)
WEIGHT	34 kg	33 kg

WATANABE
WATANABE FOODMACH CO.,LTD.

2-12-26 TSUYUHASHI NAKAGAWA-KU NAGOYA JAPAN
TEL052-361-8511 FAX052-361-8490
URL:http://www.foodmach.co.jp/

SALES AGENT