

MINCE CUTTING LINE

WMG-P22C/WPG-CCV

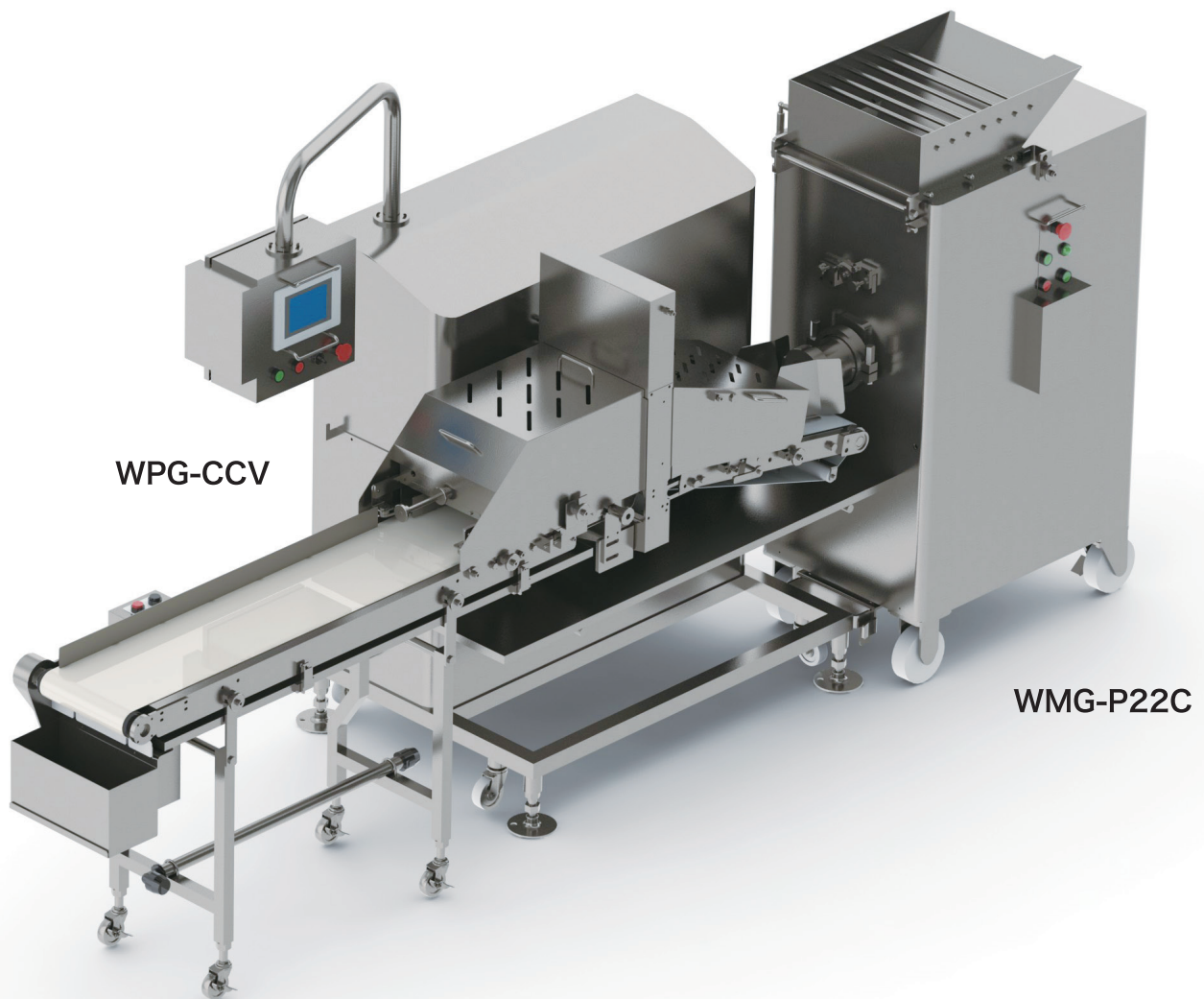

Portion your product and Packed up your cost.



WPG-CCV

WMG-P22C

SIMPLE OPERATION

No need to control, conveyor speed and cutting length. Simple setting required; only weight and product amount are.

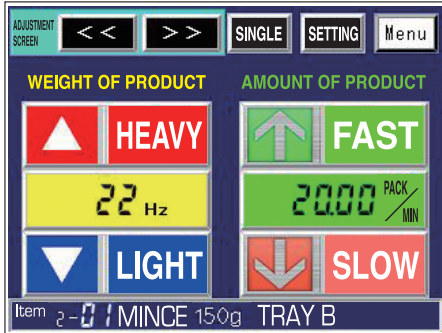

SAFETY

Opening part has all interlocks. All errors are displayed on the touch screen.

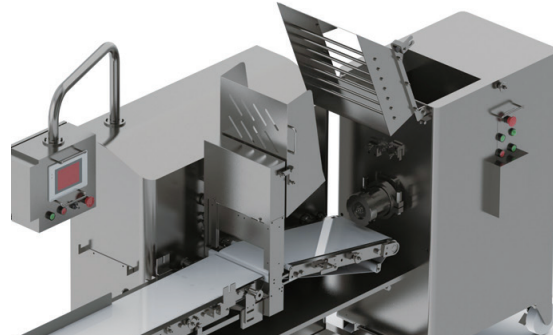

BETTER APPEARANCE

■ Better quality and operation efficiency

After chopping, make portions by SCS (Soft Cutting System). Plus HSP (Hand Side Press) making each portion like hand-made.

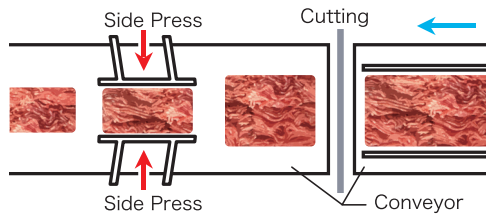

■ Smaller package is available (Optional)

With this option, you can handle even really small package, was difficult to do it.

Smaller package



BETTER HYGIENE

Wash down machine. Main unit, Paddle, Urger, Screw and Cutting conveyor belt is all detachable and easy to clean up. Only 30 min. for finishing cleaning up.



■ DRAWING Please refer to the drawing for further information .

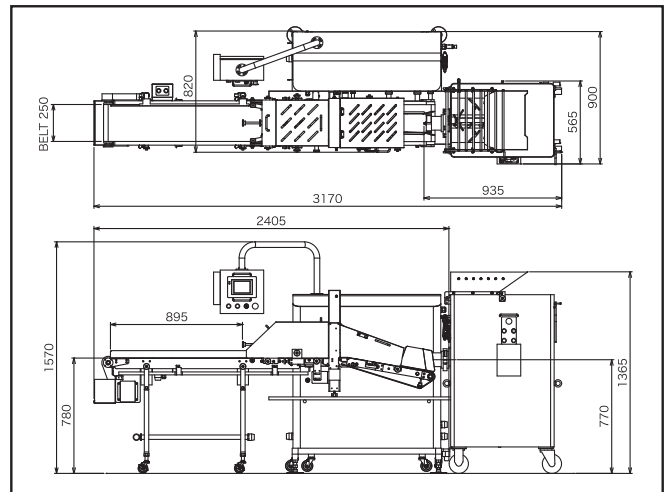

X49_Ver0100

■ SPECIFICATION

DIMENTION	W3,170×L900×H1,570mm
WEIGHT	460 kg (WMG-P22C+WPG-CCV)
PLATE SIZE	# 2 2
TEMPERATURE	-4~+0°C (Depends on products)
ELECTRIC POWER	Output 3.19kW Rated currencty 15.66A
ELECTRICITY	3phases 200V 50/60Hz 30A
AIR PRESSURE	0.5MPa / 73L/min
AIR JOINT	JSL-02

WATANABE
WATANABE FOODMACH CO.,LTD.

2-12-26 TSUYUHASHI NAKAGAWA-KU NAGOYA JAPAN
TEL 052-361-8511 FAX 052-361-8490
URL: <http://www.foodmach.co.jp/>

SALES AGENT