

Model	Compack F 400 L (G) *		
Item No.	WVC - F 400 L (G) *		
Dimensions (m m)	Width	910	
	Depth	870	
Weight (k g)	Height	1055	
		200	
Chamber size (m m)	Width	750	
	Depth	485	
Seal length	Max. 230		
Seal bar	75.0 mm x 1 bar 485 mm x 1 bar		
Pump capacity	2 bars at front and right side 100m ³ /h		

* Optional Gas flush function is available.

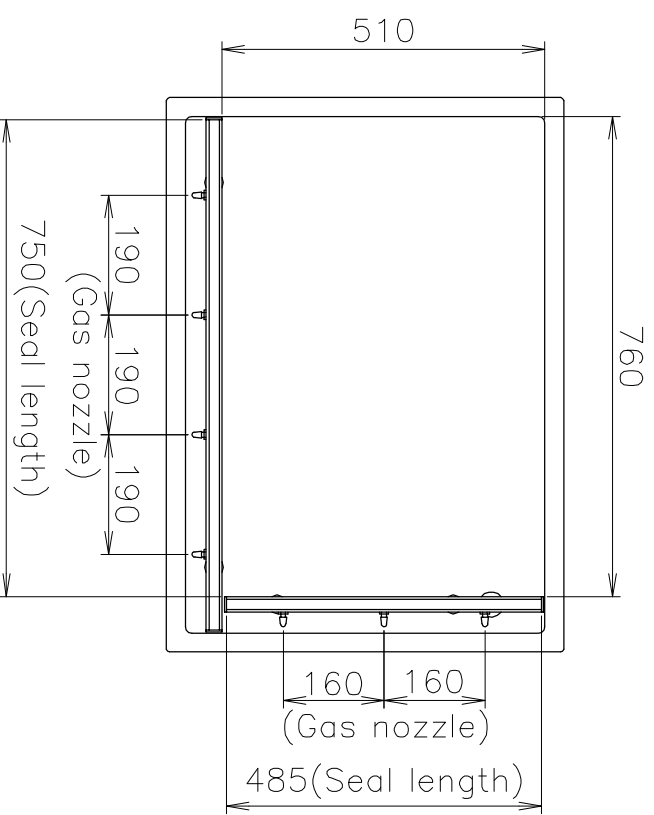

Chamber detail

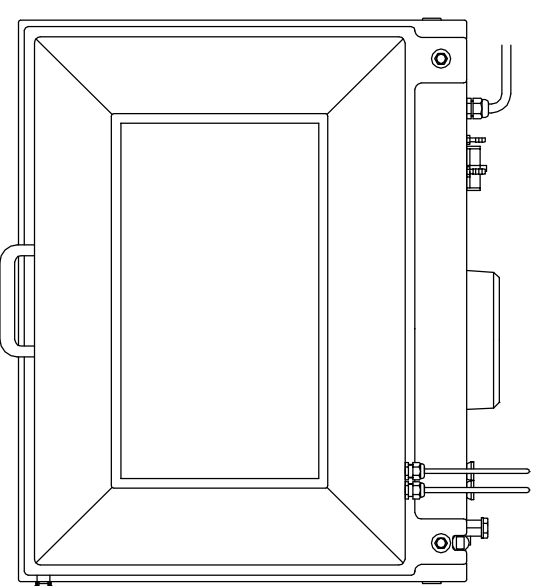
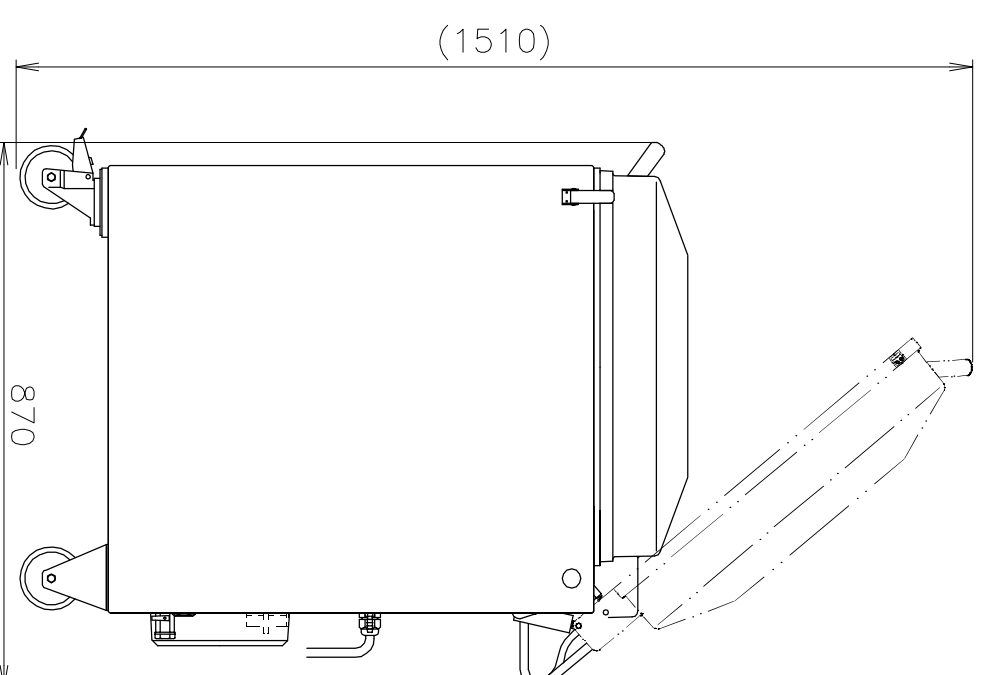
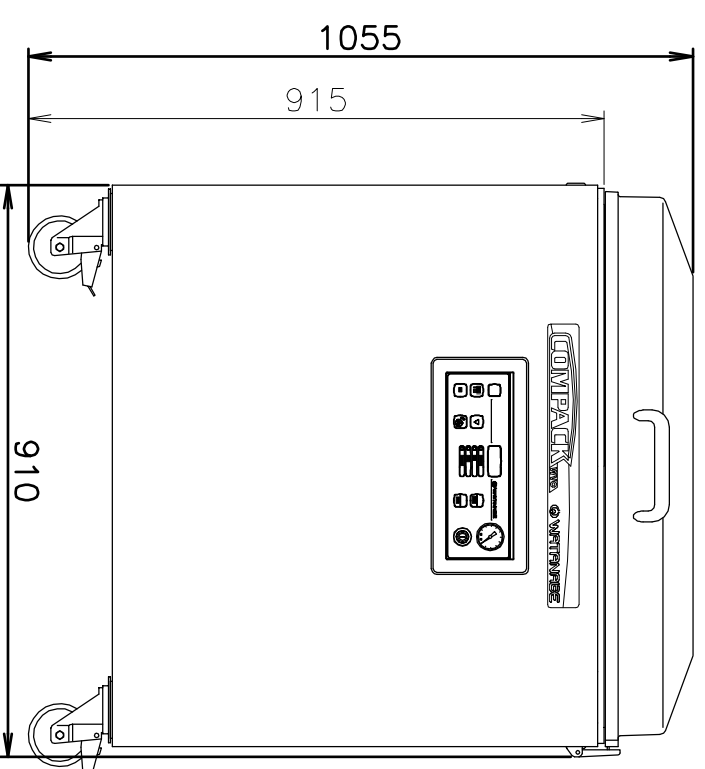

The specifications and appearance are subject to change without notice.