

BOX MINCE B32

WMG-B32



5HP!! DESIGNED FOR YOUR EASY OPERATION.



POWERFUL 5HP MOTOR!!

The capacity is 600kg/ hour!! Your production efficiency should be rising up!

EFFICIENT USE

The wider meat tray gives you more efficient operation.

WELL SANITARINESS

The barrel, feeding screw, locking ring, and meat tray are all stainless steel made.

EASY TO ATTACH/ DETACH THE BARREL AND FEEDING SCREW

Only one lever for attaching/detaching them. Easy to be cleaned up!

VARIOUS KINDS OF PLATES & KNIVES

Watanabe can also supply special Japanese plates and knives.

KEEP THE BEST FRESHNESS OF PRODUCTS

Watanabe's special barrel prevents kneaded meats and gives fresh and juicy mince.



**Freshness &
beautiful
color!!**

■ SPECIFICATION

DIMENTION	W495×D800×H1050mm
MOTOR	3P 200V 3.7kW
PROCESS AMOUNT	600 kg / h (3.2mm PLATE)
MAX. PROCESS SIZE	○φ50mm・□35mm
TRAY SIZE	W380×H70×D630mm
TEMPERATURE	-4~0°C (DEPENDS ON MEAT, SHAPE and THICKNESS)
WEIGHT	145 kg

■ DRAWING Please refer to the drawing for further information .

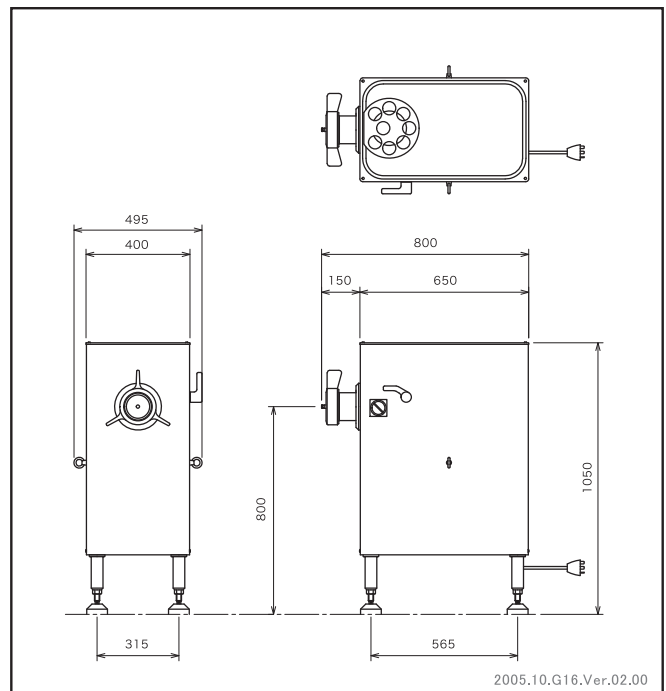

WATANABE
WATANABE FOODMACH CO.,LTD.

2-12-26 TSUYUHASHI NAKAGAWA-KU NAGOYA JAPAN
TEL052-361-8511 FAX052-361-8490
URL : <http://www.foodmach.co.jp/>

SALES AGENT