

# BIG TORNADO

## WTD-300II



**THE FIRST AMONG THE WORLD TECHNOLOGY, 'SCISSORS CUTTING STYLE' CREATED BY OUR HALF CENTURY HISTORY AND TECHNOLOGY.**



A conveyer on the picture is a normal one, the conveyer length can be changed by the option.

**Combination slicing by the rotating blade and the fixed blade !!**

**Safe to change the blade with the exclusive tool !!**



**Possible to dismantle and clean up without any tools !!**

**Water proof ; possible to clean up by splashing water !!**



**PORK/  
SHINGLING SLICE**



**PORK/  
INTERMITTENT SLICE**



**BEEF/  
JAPANESE TEPPANYAKI**



**BACON/  
SHINGLING SLICE**

### THE PATENT, "SCISSORS CUTTING STYLE"

The combination of a rotating and a fixed blade makes a clean cut of sliced products. The sharp slice like scissors.

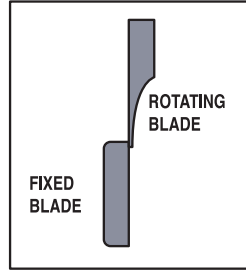

### STAINLESS STEEL MADE BODY!!

The main body is made from stainless steel. The USDA approval machine. Used in Asia, Oceania, and other countries.

## CHARACTERISTICS

### 0.1mm THICKNESS CONTROL

The combination of the sequencer and servomotor control gives the accurate feeding of product and slicing. Controllable 0.1mm thickness.

### EASY OPERATION

Thickness, shingling pitch, and intermittent are easy to be controlled by the touch panel.

### SANITARY CONSTRUCTION

Only a few minutes for dismantling the machine without any tools. The water proof construction and possible to clean up by the splashing water.

### INTERLOCK AND SAFETY DEVICE

Easy operation with the simple design. The safety device as interlock is fully set. The change of the blade is easy and safety with the exclusive tool.

### ■ SPECIFICATION

SIZE	W3,620xD1,110xH1,510mm (COVER OPEN D1,725mm)
WEIGHT	500kg
SLICE THICKNESS	0~30mm(0.1mm CONTROL)
SLICE SIZE	W300xH150mm
SLICE CAPACITY	MAX.250SLICES/MIN.
INLET CONVEYER MOTOR	3PHASE 200V 0.4kW SERVO MOTOR
OUTLET CONVEYER MOTOR	3PHASE 200V 0.09kW INVERTER CONTROL
BLADE MOTOR	3PHASE 200V 0.75kW GEARED MOTOR, INVERTER CONTROL

### ■ DRAWING Please refer to the drawing for further information .

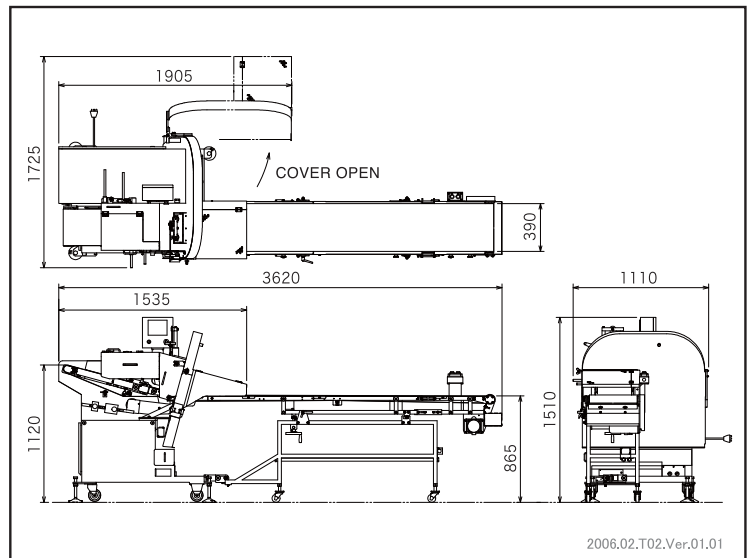

**WATANABE**  
WATANABE FOODMACH CO.,LTD.

2-12-26 TSUYHASHI NAKAGAWA-KU NAGOYA JAPAN  
TEL052-361-8511 FAX052-361-8490  
URL:<http://www.foodmach.co.jp/>

SALES AGENT